



VALID THRU 12/31/26

Published pricing is subject to change. See our website or call your rep for most current pricing.



ALL ITEMS STOCKED & READY TO SHIP!

NSK AMERICA CORPORATION



EMAX EVOLUTION RING TYPE STANDARD SET

EV410-IR



Professional-Grade Precision Finishing

Achieve vibration-free operation, consistent torque under load, and high rotational speeds.

Product Code 8231	Product Name EV410-IR
 Attachment IR-310	 Motor ENK-410S
Standard Equipment	<ul style="list-style-type: none"> • Micro Grinder (IR-310+ENK-410S) : 1 pc. • Collet $\phi 1/8"$ (CHH-3.175), • $\phi 2.35\text{mm}$ (CHH-2.35) : 1 pc. each • Controller (NE249 120) : 1 pc. • Handpiece Holder : 1 pc. • Handpiece Stand : 1 pc. • Power Supply Cord : 1 pc. • Wrench (7 x 5.1) : 1 pc. • Pin Wrench (K-233) : 2 pcs. • L Shaped Wrench (9) : 1 pc.

- Ideal for precision grinding, deburring, polishing, jewelry work, mold finishing, woodworking, and detailed engraving applications requiring smooth, high-speed operation.
- Excellent balance and motor power for smooth speed and handling.
- 1,000–40,000 RPM operation.
- Brushless micromotor technology.
- Upgraded digital display: EVOLUTION Speed Control with flash load indicator
- 1,000–40,000 RPM speed range.
- FiXpeed® speed control system.

- Ring-type quick-change handpiece.
- Compact portable controller.
- Quiet, low-vibration operation.
- Forward/reverse rotation capability.
- **Includes:** (1) Micro Grinder (IR-310+ENK-410S), (1) Collet $\phi 1/8"$ (CHH-3.175), (1) Collet $\phi 2.35\text{ mm}$ (CHH-2.35), (1) Controller (NE249 120), (1) Handpiece Holder, (1) Handpiece Stand, (1) Power Supply Cord, (1) Wrench (7 x 5.1), (2) Pin Wrenches (K-233), (1) L Shaped Wrench (#9).

Advanced Control Function

Upgraded Digital Display.
EVOLUTION Speed Control with Flash Load Indicator.



Advanced User Friendly Design

New Industrial Design.
EVOLUTION new user friendly case meets design and performance requirements.



MFR #	A&M #	LIST PRICE
EV410R	5087480	\$1,439.00

800.864.2660 | WWW.AM-IND.COM





EVOLUTION STANDARD LEVER SET

EV410-IH

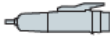

- Designed for precision polishing, grinding, deburring, engraving, and finishing applications where fast tool changes and ergonomic handling are essential.
- Lever-type ergonomic handpiece.
- Brushless motor system.
- 1,000–40,000 RPM operation.
- Digital motor speed display.
- Color-coded load meter.
- Memory speed function.
- Quiet, vibration-free operation.
- Electronic overload protection.
- Compact portable control unit.

SAVE 15%
OFF LIST PRICE!
Contact your rep or call to place your order!

Product Code 8222	Product Name EV410-IH
 Attachment IH-300	 Motor ENK-410S
Standard Equipment	<ul style="list-style-type: none"> • Micro Grinder (IR-310+ENK-410S) : 1 pc. • Collet ϕ1/8" (CHH-3.175), • ϕ2.35 mm (CHH-2.35) : 1 pc. each • Controller (NE249 120) : 1 pc. • Handpiece Holder : 1 pc. • Handpiece Stand : 1 pc. • Power Supply Cord : 1 pc. • Wrench (7 x 5.1) : 1 pc. • Pin Wrench (K-233) : 2 pcs. • L Shaped Wrench (9) : 1 pc.

Advanced Control Function

Upgraded Digital Display.
EVOLUTION Speed Control with Flash Load Indicator.



MFR #	A&M #	LIST PRICE
EV410-IH	4998078	\$1,430.00



EVOLUTION RING TYPE TORQUE SET

EV250-IR



- For heavy duty and larger tools, torque type extends to extend operation ranges.
- Lever-type ergonomic handpiece.
- Brushless motor system.
- 1,000–25,000 RPM operation.
- Digital motor speed display.
- Color-coded load meter.
- Memory speed function.
- Quiet, vibration-free operation.
- Electronic overload protection.
- Compact portable control unit.

SAVE 15%
OFF LIST PRICE!
Contact your rep or call to place your order!

Product Code 8232	Product Name EV250-IR
 Attachment IR-310	 Motor ENK-250T
Standard Equipment	<ul style="list-style-type: none"> • Micro Grinder (IR-310+ENK-250T) : 1 pc. • Collet ϕ1/8" (CHH-3.175), • ϕ2.35 mm (CHH-2.35) : 1 pc. each • Controller (NE249 120) : 1 pc. • Handpiece Holder : 1 pc. • Handpiece Stand : 1 pc. • Power Supply Cord : 1 pc. • Wrench (7 x 5.1) : 1 pc. • Pin Wrench (K-233) : 1 pc. • L Shaped Wrench (9) : 1 pc.

Advanced Control Function

Upgraded Digital Display.
EVOLUTION Speed Control with Flash Load Indicator.



MFR #	A&M #	LIST PRICE
EV250-IR	4946757	\$1,686.00

Valid thru 12/31/26 in US only. Specifications and pricing are subject to change without notice, please see our website or contact your rep for current pricing. Not responsible for typographical errors. Offers cannot be combined with any other promotional or discount offers. Please see our website for a full listing of our Terms & Conditions.