

Model No. 3818 Analog Superficial Rockwell Hardness Tester



Operation Manual

**TECHNICAL SUPPORT:
(201) 962-8352**

www.starrett.com

Operating Instructions & Parts Manual

Operating Instructions & Parts Manual

Please read and save these instructions. Read carefully before attempting to assemble, install, operate or maintain the products described. Protect yourself and others by observing all safety information. Failure to comply with instructions could result in personal injury and/or property damage! Retain Instructions for future reference.

Description

The 3818 Hardness Tester accurately measures hardness of materials in Rockwell N and T scales. Heat-treated steels are tested using a 120° diamond indenter in the N-scale. Soft/thin materials are tested using a 1/16" carbide ball indenter in the T-scale. This tester features a weight adjustment knob for quick and easy adjustments between different scales. Release/reset lever is provided for quick and accurate testing. Hardness Tester includes standard, large and V-shaped anvils for holding small, large and round or curved materials. Storage box, test blocks, 120° diamond indenter and a 1/16" carbide ball indenter.

Unpacking

Tool Kit:

- A. Large Anvil
- B. V-shaped Anvil
- C. Small Round Anvil
- D. Calibrated Test Blocks
 - 1. One each, HR15N
 - 2. One each, HR30N
 - 3. One each, HR45N
 - 4. One each, HR15T
 - 5. One each, HR30T
 - 6. One each, HR45T
- E. 120° Diamond Indenter
- F. 1/16" Carbide Ball indenter
- G. Storage Case



IMPORTANT!

Do Not Discard Shipping Crate as This May
be Needed for Future Transportation.

- **Be sure tester is level both front/back and left/right to 0.002 in/in.**

Operating Instructions & Parts Manual

General Safety Instructions

1. Never use clamps, straps, any other tooling or equipment to mount specimen to the tester anvil.
2. Always use the proper anvil supplied.
3. Be sure to use proper indenter and weight for material and hardness to be tested. (See Figure 3).

Hardness Tester Should Be Properly Maintained

1. Consult operation instructions for specific maintenance and adjusting procedures.
2. Keep the machine clean for best results.
3. Remove adjusting tools and wrenches from work space.
4. Keep all parts in working order. Check to determine that the parts will operate properly and perform their intended function.
5. Check for damaged parts. Check for alignment, binding, breakage, mounting and any other condition that may affect tool's operation.
6. Part that is damaged should be properly repaired or replaced. Do not perform makeshift repairs. (Use the parts list provided to order replacement parts.)

Basic Set-Up Information:

- 1) Remove Top crate cover from base. Carefully lift straight up to avoid scratching the side of the machine
- 2) Remove the tool kit and manual from the base of the crate
- 3) Remove plastic machine cover
- 4) With assistance, remove the two bolts under the base of the crate to remove the machine from the base.
- 5) Place machine on a sturdy vibration free table or bench. Bench should be rated for up to 500lbs.
- 6) It is recommended that the machine gets mounted to a sturdy bench as shown below.
- 7) Optional Bench/Cabinet



- 8) In order for leadscrew to be lowered to accept maximum size part, you must drill a hole in the table to allow leadscrew to travel through. This procedure is not necessary if using our cabinet stand as shown above.
- 9) Remove top cover and remove white string from extension rod (shown below). Replace Cover

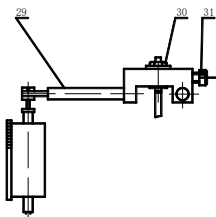

- 10) Remove back cover and begin to remove white string from all moving parts
- 11) Proceed to lower the main lead screw and remove the rubber block that is protecting the indenter housing
- 12) Clean and lubricate the elevating lead screw using light duty oil

13) Be sure tester is level both front/back and left/right to 0.002 in/in.

Operating Instructions & Parts Manual

Example of weights hung on support bar

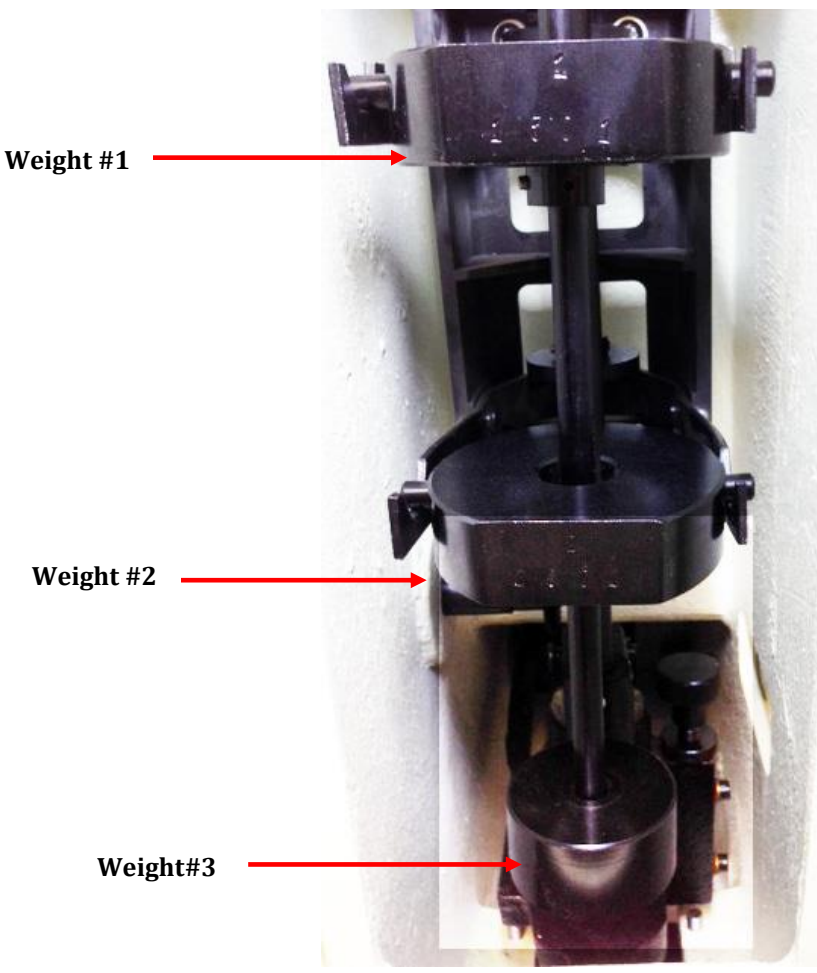

Rockwell B Indentor
1/16" Carbide Ball

Rockwell C Indentor
Diamond

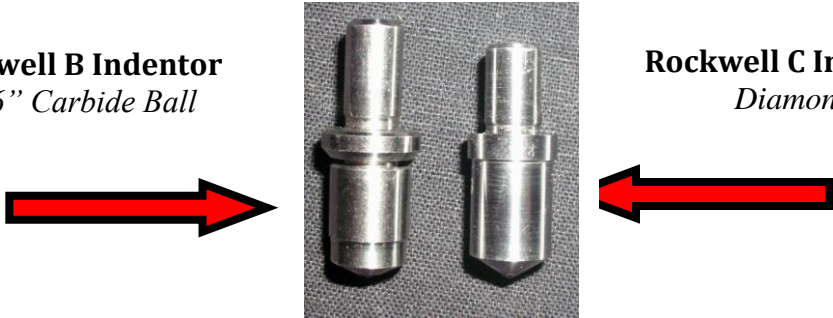

Adding Oil to the Dashpot

If when moving the Load/Unload handle and you feel it make fast hard contact or hear a suction noise then its time to check the dashpot.

On the left side of the machine (when standing in front of it) there is a small metal access plate held on by 2 small screws. Remove the screws and plate to expose the valve and reservoir.

Push the Load/Unload handle towards the back of the machine. Remove the screw #25 and carefully add high grade hydraulic oil into the hole.

Begin pulling/pushing the Load/Unload handle back and forth until any suction noise has disappeared.

Replace screw #25. Replace access plate.

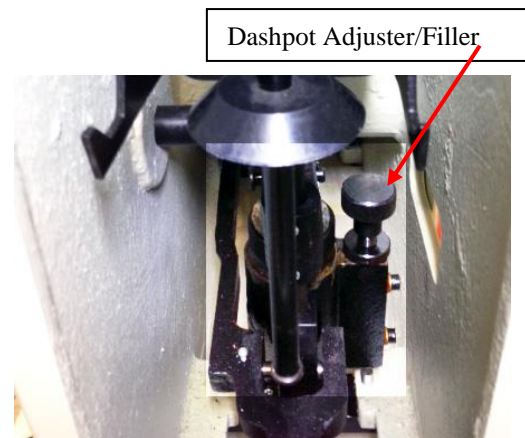
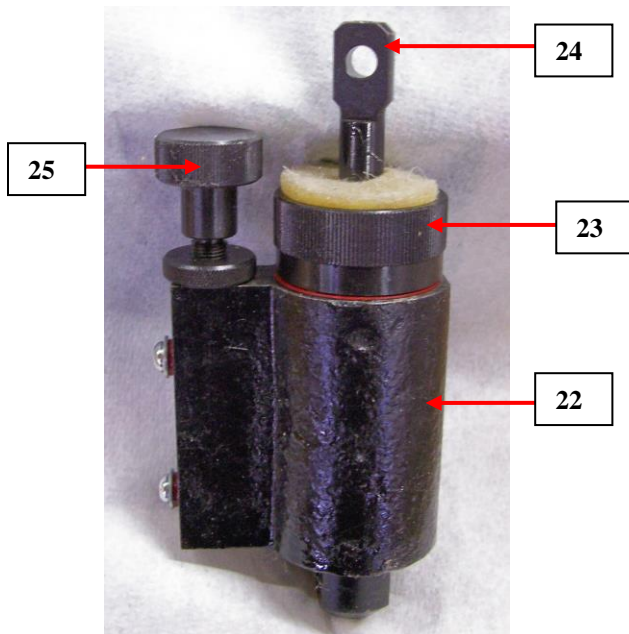

Operating Instructions & Parts Manual

Seating Your Diamond:

Caution: To ensure accuracy, mount the indenter by sliding it in the holder as far as possible and then securing the indenter by tightening the set screw finger-tight only.

Place HRC test block on the small round anvil and begin by turning the handwheel clockwise until the block just touches the diamond. At this point, continue rotating the handwheel until the large needle goes around approx. 3 revolutions. Let the machine sit idle for a few seconds and then loosen the set screw. Wait a few more seconds and then tighten the set screw back up. This will allow the diamond to be “seated” in the shank. Take the load off by turning the handwheel counter-clockwise and you can begin following instructions below.

Rotate the weight adjustment knob until the required weight scale is aligned with the alignment mark on the frame of the machine.

1. Prepare the test specimen properly. Be sure that the top and bottom surfaces of the specimen are clean and free of any grease, oil dirt, etc and free of any burrs or debris.
2. For small specimens (under 3" maximum length or diameter) use the small round anvil. Use the large anvil for larger specimens. Use the V-shaped anvil for round or curved specimens.

Warning!

Do not test any specimen that cannot be safely and properly positioned on and supported by the tester anvil.

Operation:

Determine the proper indenter, scale and weight for the material hardness to be tested (see Figure 3). Mount the required indenter in the indenter holder using the set screw (Fig. 6, Ref. Nos. 27 and 28) on the side of the holder.

Test Procedure

Test procedure consists of a preload of the specimen using the force of the elevation screw and a test load using the weights and lever arm assembly. Be sure that the weight reset handle is in rest (“unload”) position.

1. Mount specimen on required anvil. Rotate the elevation screw threaded collar clockwise slowly until the specimen contacts the indenter. Be sure to position specimen so the indenter contacts clean, untested material.
2. Preload the specimen by rotating the leadscrew collar slowly until the large needle on the dial indicator rotates two to three (2-3) revolutions. Stop rotation of handwheel when the large needle is within 3 hash marks of vertical(TDC)

Caution: As the large needle is properly rotated 2-3 revolutions, the small needle rotates counterclockwise 90° to vertical at the red dot. If the large needle overshoots vertical by more than 5 hash marks, the test is invalid and must be repeated from step 1.

3. Rotate the bezel so that the hash mark at the “0” mark at the top of the dial is aligned with the large needle.
4. Pull the weight release handle to apply the major load. Wait until the large needle stops rotating, approx. 5-8 seconds. This 5-8 second “dwell” time can be adjusted by turning valve on dashpot.
5. Slowly push the weight reset handle back until it resets and locks in the reset position.
6. Read the material hardness from the required scale on the dial.
7. Rotate the handwheel counterclockwise to lower and release the specimen.

Fine Adjustment:

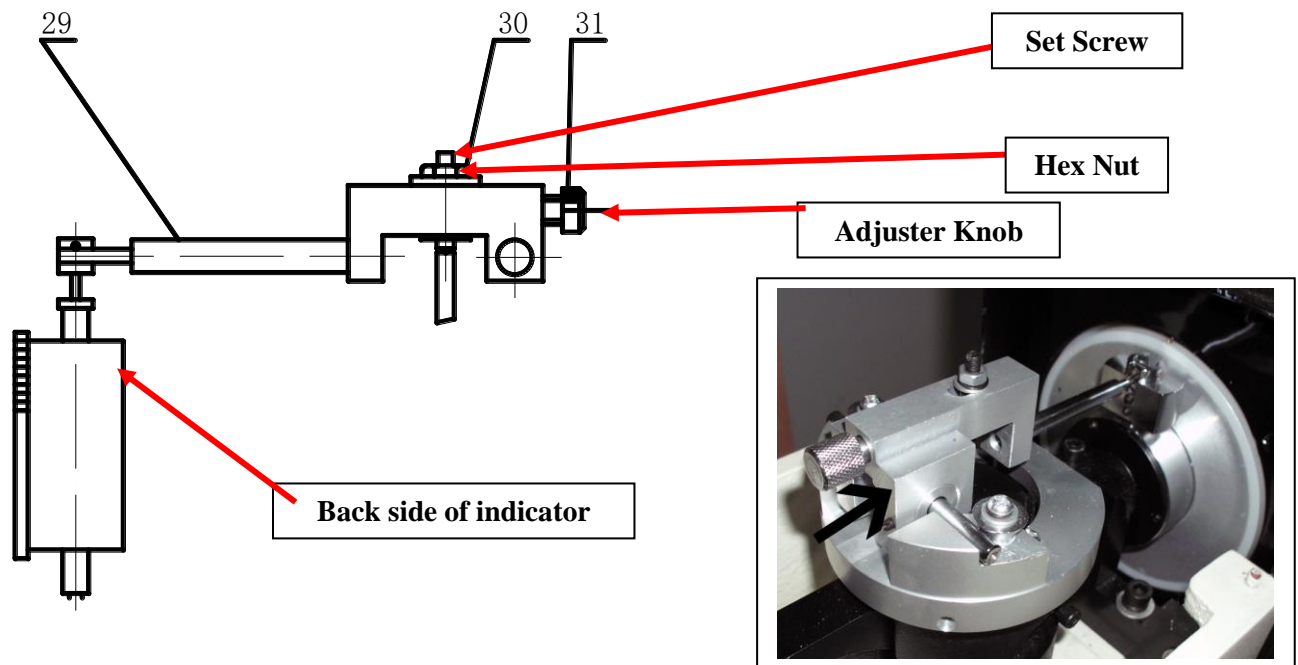

Please be sure to make very slight adjustments when calibrating the 3818 as this machine is extremely sensitive to any movement.

Remove the top cover off the 3818.

Adjusting the set screw that controls the Indicator needle starting point:

Carefully hold the set screw with a thin blade regular screwdriver. While holding this screw steady, carefully loosen the set screw hex nut. Making a very slight turn Counter-Clockwise on the set screw, you will see the large needle on the dial begin to turn counter-clockwise on the dial. Continue turning until there is no more contact between the set screw and needle adjuster.

At that point turn the set screw until it just touches the adjuster and snug the hex nut back in place while holding the set screw to prevent it from turning.

Take a minimum of 3 tests on your test block to make sure the machine is reading correctly. If readings are low, you will need to back off on the set screw a little more. The opposite if readings are high.

Operating Instructions & Parts Manual

Maintenance

1. If large needle on the dial indicator rotates suddenly at first and then slows during a test, then the dash pot may be low on oil. To fill the dash pot, go to Page 5 in this manual and follow instructions. Bleed the air from the dash pot by manually raising and lowering the dash pot piston until all air bubbles have been released from under the piston.
2. Be sure elevation screw and threaded collar are clean and lubricated. Lubricate with general purpose wheel bearing grease.
3. Keep top of leadscrew, collar and anvils clean and free of grease, oil, dirt, burrs, etc.
4. Use the test blocks periodically to check tester accuracy.

Troubleshooting Chart

Symptom	Possible cause(s)	Corrective Action
Incorrect hardness measurement	<ol style="list-style-type: none"> 1. Contaminants effecting measurement 2. Elevation screw cover & top, are interfering with specimen, anvil or elevation screw. 3. Indentor is damaged. 4. Dash pot is low on oil. 	<ol style="list-style-type: none"> 1. Be sure the anvil, top of elevation screw, threaded collar, indentor and specimen are all clean and free of oil, grease, dirt, shavings, debris, etc. 2. Be sure elevation screw cover and top is clean and free of any dirt, oil, grease, etc. Position cover properly on the elevation screw. 3. Inspect indentor for damage, replace diamond indentor if chipped or broken, replace 1/16" steel ball if deformed or damaged. 4. Refill dash pot, see Maintenance, above.
When using the test block, a different hardness is measured at different locations on the block.	<ol style="list-style-type: none"> 1. Burrs on bottom of test block. 2. Air trapped under test block. 	<ol style="list-style-type: none"> 1. Use oil sharpening stone to remove burrs. 2. When testing different locations on a test block, slide test block on anvil, maintaining contact between anvil and block.
Dial indicator needle rotates too fast at start of test	<ol style="list-style-type: none"> 1. Dash pot is low on oil. 	<ol style="list-style-type: none"> 1. Refill dash pot See Maintenance, above.

Operating Instructions & Parts Manual

ASTM Hardness Conversion Chart Rockwell C Hardness Range

Approximate Hardness Conversion Numbers for Non-Austenitic Steels, According to ASTM E-140

The Conversion Values contained herein should be considered approximate only and may be inaccurate for specific applications

C	A	D	15N	30N	45N	Vickers	Knoop	Brinell	Tensile
150 kgt diamond	60 kgt diamond	100kgt diamond	15kgt diamond	30 kgt diamond	45 kgt diamond	Hardness	Hardness 500gr and over	Hardness 3000kgt 10mm ball	Strength 1000 lbs/ square in
68	85.6	76.9	93.2	84.4	75.4	940	920
67	85.0	76.1	92.9	83.6	74.2	900	895
66	84.5	75.4	92.5	82.8	73.3	865	870
65	83.9	74.5	92.2	81.9	72.0	832	846	(739)	
64	83.4	73.8	91.8	81.1	71.0	800	822	(722)	
63	82.8	73.0	91.4	80.1	69.9	772	799	(705)	
62	82.3	72.2	91.1	79.3	68.8	745	776	(688)	
61	81.8	71.5	90.7	78.4	67.7	720	754	(670)	
60	81.2	70.7	90.2	77.5	66.6	697	732	(654)	
59	80.7	69.9	89.8	76.6	65.5	674	710	(634)	351
58	80.1	69.2	89.3	75.7	64.3	653	690	615	338
57	79.6	68.5	88.9	74.8	63.2	633	670	595	325
56	79.0	67.7	88.3	73.9	62.0	613	650	577	313
55	78.5	66.9	87.9	73.0	60.9	595	630	560	301
54	78.0	66.1	87.4	72.0	59.8	577	612	543	292
53	77.4	65.4	86.9	71.2	58.6	560	594	525	283
52	76.8	64.6	86.4	70.2	57.4	544	576	512	273
51	76.3	63.8	85.9	69.4	56.1	528	558	496	264
50	75.9	63.1	85.5	68.5	55.0	513	542	481	255
49	75.2	62.1	85.0	67.6	53.8	498	526	469	246
48	74.7	61.4	84.6	66.7	52.5	484	510	455	237
47	74.1	60.8	83.9	65.8	51.4	471	495	443	229
46	73.6	60	83.5	64.8	50.3	458	480	432	221
45	73.1	59.2	83.0	64.0	49.0	446	466	421	215
44	72.5	58.5	82.5	63.1	47.8	434	452	409	208
43	72.0	57.7	82.0	62.2	46.7	423	438	400	201
42	71.5	56.9	81.5	61.3	45.5	412	426	390	195
41	70.9	56.2	80.9	60.4	44.3	402	414	381	188
40	70.4	55.4	80.4	59.5	43.1	392	402	371	182
39	69.9	54.6	79.9	58.6	41.9	382	391	362	177
38	69.4	53.8	79.4	57.7	40.8	372	380	353	171
37	68.9	53.1	78.8	56.8	39.6	363	370	344	166
36	68.4	52.3	78.3	55.9	38.4	354	360	336	161
35	67.9	51.5	77.7	55.0	37.2	345	351	327	156
34	67.4	50.8	77.2	54.2	36.1	336	342	319	152
33	66.8	50.0	76.6	53.3	34.9	327	334	311	149
32	66.3	49.2	76.1	52.1	33.7	318	326	301	146
31	65.8	48.4	75.6	51.3	32.5	310	318	294	141
30	65.3	47.7	75.0	50.4	31.3	302	311	286	138
29	64.8	47.0	74.5	49.5	30.1	294	304	279	135
28	64.3	46.1	73.9	48.6	28.9	286	297	271	131
27	63.8	45.2	73.3	47.7	27.8	279	290	264	128
26	63.3	44.6	72.8	46.8	26.7	272	284	258	125
25	62.8	43.8	72.2	45.9	25.5	266	278	253	123
24	62.4	43.1	71.6	45.0	24.3	260	272	247	119
23	62.0	42.1	71.0	44.0	23.1	254	266	243	117
22	61.5	41.6	70.5	43.2	22.0	248	261	237	115
21	61.0	40.9	69.9	42.3	20.7	243	256	231	112
20	60.5	40.1	69.4	41.5	19.6	238	251	226	110

Hardness values in Brackets are outside the range recommended for Brinell testing in ASTM E-10. The above tables is from ASTM E-110 except values for E-scale and Tensile Strength which are not from or according to ASTM Standards.

Operating Instructions & Parts Manual

ASTM Hardness Conversion Chart Rockwell B Hardness Range

*Approximate Hardness Conversion Numbers for Non-Austenitic Steels,
according to ASTM E-140. The conversion values contained herein should be
considered approximate only and may be inaccurate for specific applications.*

B	Rockwell	E	Superficial Rockwell			Vickers Hardness	Knoop Hardness	Brinell Hardness	Tensile Strength	Brinell Hardness
	A		15T	30T	45T					
100kgf 1/16"ball	60 kgf diamond	100 kgf 1/8" ball	15 kgf 1/16" ball	30 kgf 1/16"ball	45 kg f 1/16" ball		500gf and over	3000 kgf 10mm ball	1000 lbs/ square in	500 kgf 10mm ball
100	61.5		93.1	83.1	72.9	240	261	240	116	201
99	60.9		82.8	82.5	71.9	234	246	234	114	195
98	60.2		92.5	81.8	70.9	228	241	228	109	189
97	59.5		92.1	81.1	69.9	222	236	222	105	184
96	58.9		91.8	80.4	68.9	216	231	216	102	179
95	58.3		91.5	79.8	67.9	210	226	210	100	175
94	57.6		91.2	79.1	66.9	205	221	205	98	171
93	57		90.8	78.4	65.9	200	216	200	94	167
92	56.4		90.5	77.8	64.8	195	211	195	92	163
91	55.8		90.2	77.1	63.8	190	206	190	90	160
90	55.2		89.9	76.4	62.8	186	201	186	89	157
89	54.6		89.5	76.8	61.8	180	196	180	88	164
88	64.0		89.2	75.1	60.8	176	192	176	86	151
87	53.4		88.9	74.4	59.8	172	188	172	84	148
86	52.8		88.6	73.8	58.8	169	184	169	83	145
85	52.3		88.2	73.1	57.8	165	180	165	82	142
84	51.7		87.9	72.4	56.8	162	176	162	81	140
83	51.1		87.6	71.8	55.8	159	173	159	80	137
82	50.6		87.3	71.1	54.8	156	170	156	76	135
81	50		86.9	70.4	53.8	153	167	153	73	133
80	49.5		86.6	69.7	52.8	150	164	150	72	130
79	48.9		86.3	69.1	51.8	147	161	147	70	128
78	48.4		86.0	68.4	50.8	144	158	144	69	126
77	47.9		85.6	67.7	49.8	141	155	141	68	124
76	47.3		85.3	67.1	48.8	139	152	139	67	122
75	46.8		86.0	66.4	47.8	137	150	137	66	120
74	46.3		84.7	65.7	46.8	135	147	135	66	118
73	45.8		84.3	65.1	45.8	132	145	132	64	116
72	45.3		84.0	64.4	44.8	130	143	130	63	114
71	44.8	100	83.7	63.7	43.8	127	141	127	62	112
70	44.3	99.5	83.4	63.1	42.8	125	139	125	61	110
69	43.8	99.0	83.0	62.4	41.8	123	137	123	60	109
68	43.3	98.0	82.7	61.7	40.8	121	135	121	59	108
67	42.8	97.5	82.4	61	39.8	119	133	119	58	106
66	42.3	97.0	82.1	60.4	38.7	117	131	117	57	104
65	41.8	96.0	81.8	59.7	37.7	116	129	116	56	102
64	41.4	95.5	81.4	59	36.7	114	127	114		100
63	40.9	95.0	81.1	58.4	35.7	112	125	112		99
62	40.4	94.5	80.8	57.7	34.7	110	124	110		98
61	40.0	93.5	80.5	57.0	33.7	108	122	108		96
60	39.5	93.0	80.1	56.4	32.7	107	120	107		95
59	39.0	92.5	79.8	55.7	31.7	106	118	106		94
58	38.6	92.0	79.5	55	30.7	104	117	104		92
57	38.1	91.0	79.2	54.4	29.7	103	115	103		91
56	37.7	90.6	78.8	53.7	28.7	101	114	101		90
55	37.2	90.0	78.6	53.0	27.7	100	112	100		89
54	36.8	89.5	78.2	52.4	26.7		111			87
53	36.3	89.0	77.9	51.7	26.7		110			86
52	35.9	88.0	77.5	51.0	24.7		109			85
51	35.5	87.6	77.2	50.3	23.7		108			84
50	35.0	87.0	76.9	49.7	22.7		107			83

Operating Instructions & Parts Manual

49	34.6	86.5	76.6	49.0	21.7	106	82
48	34.1	85.5	76.2	48.3	20.7	105	81
47	33.7	85	75.9	47.7	19.7	104	80
46	33.3	84.6	76.6	47.0	18.7	103	80
45	32.9	84	76.3	46.3	17.7	102	79
44	32.4	83.5	74.9	45.7	16.7	101	78
43	32.0	82.5	74.6	45.0	15.7	100	77
42	31.6	82	74.3	44.3	14.7	99	76
41	31.2	81.5	74.0	43.7	13.6	98	75
40	30.7	81	73.6	43.0	12.6	97	75
39	30.3	80	73.3	42.3	11.6	96	74
38	29.9	79.5	73.0	41.6	10.6	95	73
37	29.5	79	72.7	41.0	9.6	94	72
36	29.1	78.5	72.3	40.3	8.6	93	72
35	28.7	78.0	72.0	39.6	7.6	92	71
34	28.2	77.0	71.7	39.0	6.6	91	70
33	27.8	76.6	71.4	38.3	5.6	90	69
32	27.4	76.0	71.0	37.6	4.6	89	69
31	27.0	75.5	70.7	37.0	3.6	88	68
30	26.6	75.0	70.4	36.3	2.6	87	67

Hardness values in brackets are outside the range recommended for Brinell testing in ASTM E-10. The above table is from ASTM E-110 except values for E-scale and Tensile Strength which are not from or according to ASTM Standards.

Reprinted from the Annual Book of ASTM Standards, copyright American Society for Testing and Materials.
100 Barr Harbor Drive, West Conshohocken, PA 19428-2959

Operating Instructions & Parts Manual

ASTM Hardness Minimum Thickness Requirements

Minimum allowable thickness for a corresponding hardness in the respective scales

Minimum Thickness Inch	Minimum Thickness mm	Rockwell C	Rockwell A	Rockwell B	Superficial 15N	Superficial 30N	Superficial 45N	Superficial 15T	Superficial 30T	Superficial 45T
0.006	0.15
0.008	0.20	92
0.010	0.25	90	91
0.012	0.30	88	82	77	86
0.014	0.36	83	78.5	74	81	80	...
0.016	0.41	...	86	...	76	74	72	75	72	71
0.018	0.46	...	84	...	68	66	68	68	64	62
0.020	0.51	...	82	57	63	...	55	53
0.022	0.56	69	79	47	58	...	45	43
0.024	0.61	67	76	94	51	...	34	31
0.026	0.66	65	71	87	37	18
0.028	0.71	62	67	80	20	4
0.030	0.76	57	60	71
0.032	0.81	52	...	62
0.034	0.86	45	...	52
0.036	0.91	37	...	40
0.038	0.96	28	...	28
0.040	1.02	20

**TECHNICAL SUPPORT:
(201) 962-8352**

www.starrett.com

Operating Instructions & Parts Manual

Rockwell Hardness: Scale/Indenter/Load Chart

Scale Symbol	Indenter Type	Preliminary Force N (kgf)	Total Force N (kgf)	Typical Applications
A	Spheroconical Diamond	98.07 (10)	588.4 (60)	Cemented carbides, thin steel, and shallow case hardened steel
B	1/16" Carbide Ball	98.07 (10)	980.7 (100)	Copper alloys, soft steels, aluminum alloys, malleable iron, etc.
C	Spheroconical Diamond	98.07 (10)	1471 (150)	Steel, hard cast irons, pearlitic malleable iron, titanium, deep case hardened steel, other harder than HRB 100
D	Spheroconical Diamond	98.07 (10)	980.7 (100)	Thin steel and medium case hardened steel, and pearlitic malleable iron
E	1/8" Carbide Ball	98.07 (10)	980.7 (100)	Cast Iron, Aluminum and magnesium alloys, and bearing metals
F	1/16" Carbide Ball	98.07 (10)	588.4 (60)	Annealed copper alloys and thin soft sheet metals
G	1/16" Carbide Ball	98.07 (10)	1471 (150)	Malleable irons, copper-nickel-zinc and cupro-nickel alloys
H	1/8" Carbide Ball	98.07 (10)	588.4 (60)	Aluminum, zinc and lead
K	1/8" Carbide Ball	98.07 (10)	1471 (150)	Bearing Metals and other very soft or thin materials. Use smallest ball and heaviest load that doesn't give anvil effect.
L	1/4" Carbide Ball	98.07 (10)	588.4 (60)	
M	1/4" Carbide Ball	98.07 (10)	980.7 (100)	
P	1/4" Carbide Ball	98.07 (10)	1471 (150)	
R	1/2" Carbide Ball	98.07 (10)	588.4 (60)	
S	1/2" Carbide ball	98.07 (10)	980.7 (100)	
V	1/2" Carbide ball	98.07 (10)	1471 (150)	
15N	Spheroconical Diamond	29.42 (3)	147.1 (15)	Similar to A, C and D scales but for thinner gage material.
30N	Spheroconical Diamond	29.42 (3)	294.2 (30)	
45N	Spheroconical Diamond	29.42 (3)	441.3 (45)	
15T	1/16" Carbide Ball	29.42 (3)	147.1 (15)	Similar to B, F and G scales but for thinner gage material.
30T	1/16" Carbide Ball	29.42 (3)	294.2 (30)	
45T	1/16" Carbide Ball	29.42 (3)	441.3 (45)	
15W	1/8" Carbide Ball	29.42 (3)	147.1 (15)	Very Soft Material
30W	1/8" Carbide Ball	29.42 (3)	294.2 (30)	
45W	1/8" Carbide Ball	29.42 (3)	441.3 (45)	
15X	1/4" Carbide Ball	29.42 (3)	147.1 (15)	
30X	1/4" Carbide Ball	29.42 (3)	294.2 (30)	
45X	1/4" Carbide Ball	29.42 (3)	441.3 (45)	
15Y	1/2" Carbide Ball	29.42 (3)	147.1 (15)	
30Y	1/2" Carbide Ball	29.42 (3)	294.2 (30)	
45Y	1/2" Carbide Ball	29.42 (3)	441.3 (45)	

Operating Instructions & Parts Manual

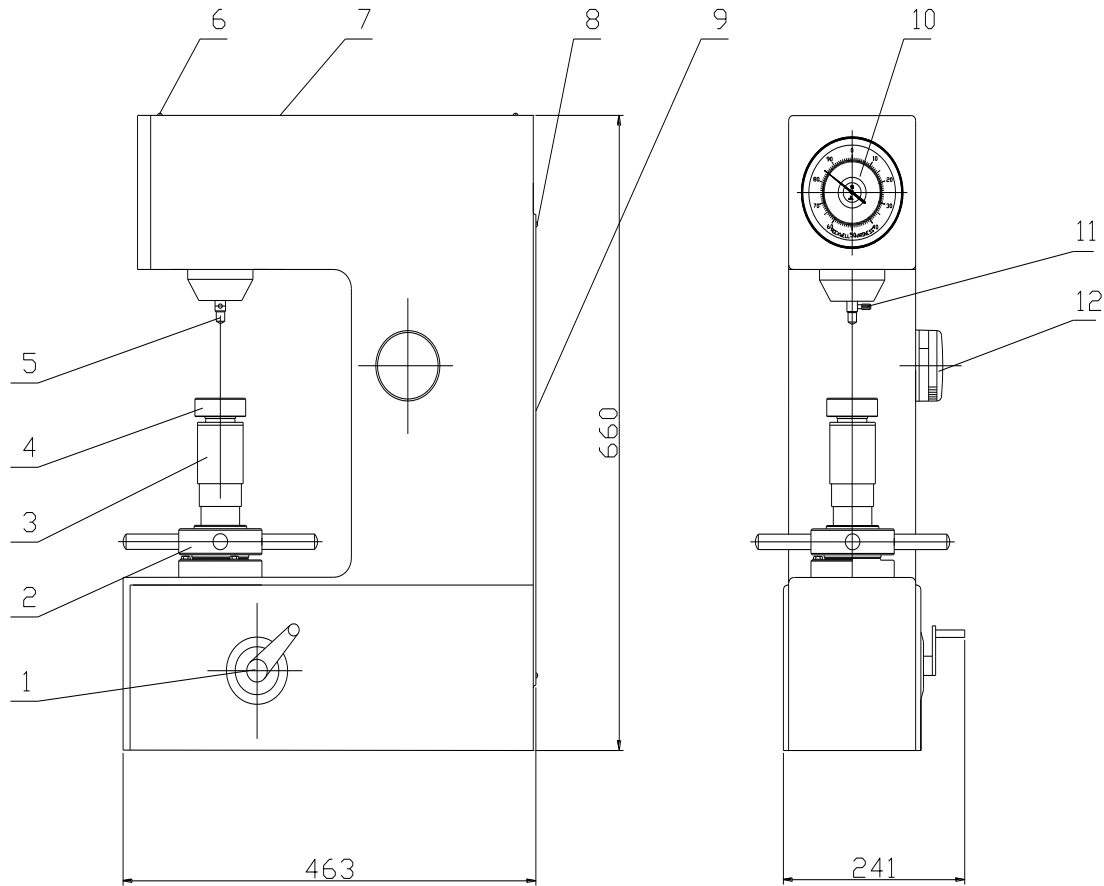

1. Load/Unload Handle 2. Turn wheel 3. Lifting Screw Cover 4. Anvil 5. Indenter 6. Screws
7. Top cover 8. Screws 9. Rear cover 10. Indicator 11. Indenter Locking Screw 12. Weight Load Handwheel

**TECHNICAL SUPPORT:
(201) 962-8352**

www.starrett.com